



ST27

Track Loader

Small But Fierce

The ST27 offers a compact design, outstanding visibility and operator comfort features that make it a perfect fit for any job. The trim package, low weight and ability to lift heavier loads, compared to similar machines in this class, make it especially productive for smaller job sites. The ST27 is powered by a Kohler turbocharged engine offering high horsepower, superior torque and large fuel capacity to operate longer and get more done. The vertical lift arms allow excellent lift and dump height for maximum efficiency and flexibility on the job site.

Highlights

- Controls for Every Operator
- Maintenance and Filter Free After-treatment
- Expansive Maintenance Access

Technical Data

Hydraulic

Flow rate	19.3 gal/mi
Flow rate max.	28.8 gal/mi
Auxiliary relief pressure	3,480.0 psi

Mechanical - Output Details

Ground Pressure (standard track)	4.4 psi
Break Out Force Bucket	5,404.2 lbf
Break Out Force Lift Arm	4,783.3 lbf
Tractive Effort max. at 100% effective force	7,476.9 lbf
Bucket Roll Back	2.1 s
Bucket Roll Out	2.2 s
Lift Arm Raise	3.3 s
Lift arm lower	2.8 s
Travel speed stage 1	6.4 m/H
Travel speed stage 2	9.1 m/H

Mechanical Details

Overall Length without bucket	102.5 "
Overall Length with Bucket	132.4 "
Overall width without bucket	60.0 "
Overall height to top of ROPS	79.8 "
Bucket Hinge Pin Height	119.9 "
Bucket roll back at ground	30.0 °
Bucket roll back at maximum height	95.0 °

Angle of departure	29.0 °
Bucket dump height at maximum height	155.3 "
Bucket dump angle at maximum height	37.0 °
Operating weight	7,350.2 lb
Track width	12.6 "
Ground clearance	8.5 "
Length of Track on Ground	53.1 "
Dump reach at maximum height	39.1 "

Engine

Cooling	Water-cooling
Cylinder	4.0
Oil filling max.	2.5 gal US
Power rating max.	74.0 hp
Operating Engine speed	2,600.0 1/min
Starter battery Voltage	12.0 V
Manufacturer	Kohler
Engine designation	KDI2504TCR

Operating Fluids

Cooling fluid volume	13.7 qt US
Hydraulic fluid volume	30.6 qt US
Fuel Tank capacity	27.2 gal US

Chassis

Tip Load	5,599.7 lb
----------	------------

Rated Operating Capacity at 35% Tip 1,889.4 lb

Load

Dimensions

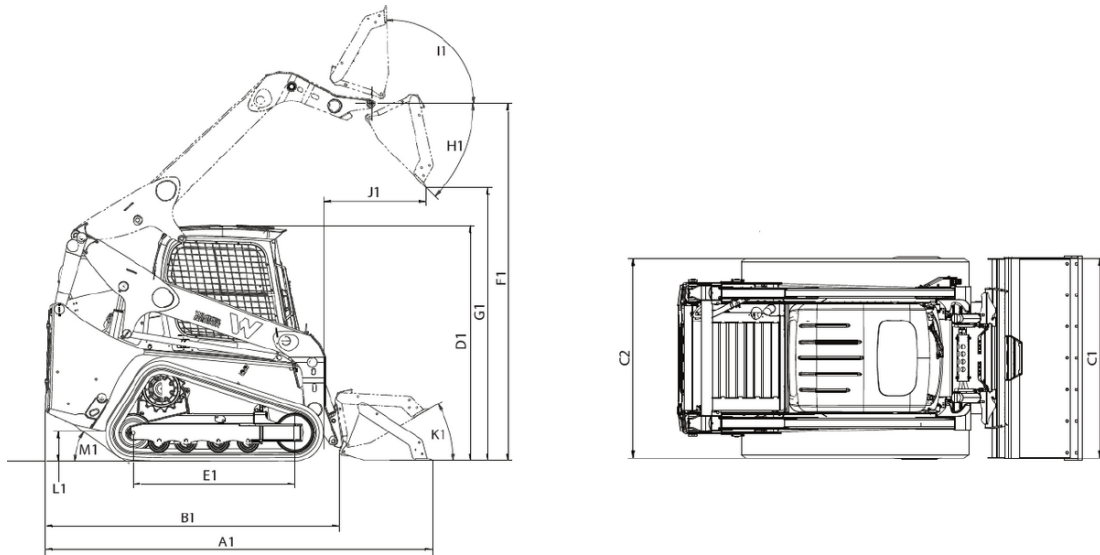

A1	Overall length with bucket	132.4 in
B1	Overall length without bucket	102.5 in
C1	Overall width with bucket	63.5 in
C2	Overall width without bucket	102.5 in
D1	Overall height	79.8
E1	Length of track on ground	53.2 in
F1	Hinge pin height	120 in
G1	Dump height max.	94.3 in
H1	Dump angle	37 °
I1	Bucket rollback at max. stroke height	95.5 °
J1	Dump reach	39.2 in
K1	Bucket rollback at ground level	30 °
L1	Ground clearance	8.5 in
M1	Angle of departure	29.9 °