

CAB & INTERIOR	STD	OPT
Alternator, 95Amp	●	
Alarms, audible and visual		
Air filter clogging	●	
Transmission error	●	
Battery voltage	●	
Brake oil pressure	●	
Engine oil pressure	●	
Parking brake	●	
Fuel level	●	
Hydraulic oil temperature	●	
Coolant temperature	●	
Transmission oil temperature	●	
Service brake oil pressure	●	
Coolant level	●	
water in fuel	●	
Alarm, back-up	●	
Batteries, PT		
900 CCA, 12V, (2)	●	
Gauges		
Engine coolant temperature	●	
Fuel level	●	
Speedometer	●	
Transmission oil temperature	●	
Horn, electric		
Indicator lights		
T/C lock up		●
High beam	●	
Turn signal	●	
FNR joystick steering		●
Pilot cut off	●	
LCD Display		
Clock and fault code	●	
Operating hour counter	●	
Engine rpm	●	
Transmission gear range	●	
Indicator	●	
Job time and distance	●	
Temperature (coolant, hydraulic oil, t/m oil)	●	
Lighting system		
LED dome light	●	
2 stop and tail lights	●	
4 turn signals	●	
Brake lights(counterweight)	●	
2 head lights on front tower	●	
2 working lights on front roof	●	
4 working lights on front roof, 2 working lights on rear roof		●
4 working lights(2xenon) on front roof, 2 working lights on rear roof		●
4 working lights(LED) on front roof, 2 working lights(LED) on rear roof		●
2 working lights on grill	●	
Switches		
Hazard	●	
Ignition	●	
Parking	●	
Battery master switch	●	
FNR		●
Diff. lock		●
SCR cleaning / inhibit	●	
Secondary steering test		●
Pilot cut off	●	
Membrane Switches in monitor		
Main light	●	
Work light	●	
Auto grease		●
Quick coupler		●
Ride control		●
Work load	●	
Becon lamp		●
rear wiper	●	
Mirror heat		●
Auto position	●	
Fine modulation		●

CAB & INTERIOR	STD	OPT
Cab (sound suppressed and pressurized) with		
cigar lighter & ashtray	●	
coat hook	●	
Automatic climate control		
air conditioner & heater	●	
defroster	●	
intermittent wiper and washer, front and rear	●	
Seat		
2" retractable seat belt & adjustable	●	
2" static seat belt & adjustable mechanical suspension (heated)		●
3" static seat belt & adjustable adjustable mechanical suspension		●
2" retractable seat belt & adjustable air suspension (heated)		●
Personal storage space		
Console box	●	
Holder, can and cup	●	
Rear view mirrors (1 inside)	●	
Rear view mirrors (2 outside)	●	
Rear view mirrors(2 outside, Heated)		●
Steering column, tilt and telescopic	●	
Steering wheel with knob	●	
Roller type sunshade (front window)	●	
Roller type sunshade (rear window)		●
Tinted safety glass	●	
One door cab	●	
Magazine pocket	●	
Pedals		
One accelerator pedal	●	
One brake pedal	●	
Dual-Brake pedal		●
Radio/USB player	●	
Rubber floor mat	●	
Wrist rest	●	
24-volt to 12-volt DC converter (20A)		●
ENGINE		
Antifreeze		●
Engine, Cummins QSB6.7		
Tier4 Final / Stage 4	●	
Engine enclosure, lockable	●	
Engine fuel priming pump	●	
Fan guard	●	
Fuel/water separator	●	
Clean emission module		
DOC and SCR	●	
Rain cap, engine air intake	●	
3 Stage Air precleaner		●
Radiator	●	
Starting aid (air intake heater)	●	
Fuel heater	●	
Fuel heater (Dual)		●
Coolant level sight gauge	●	
Engine oil level dipstick gauge	●	
Air cleaner with auto dust eject	●	
POWER TRAIN		
Brakes : Service, enclosed wet-disc	●	
Parking brake	●	
Torque converter	●	
Transmission F4 / R3, computer controlled, electronic soft shift, auto-shift and kick-down features included		●
Transmission F5 / R3 with lock-up clutch		●
Transmission oil sight level	●	
Limited slip differential (front, rear)		●
Transmission oil cooler	●	
Transmission oil cooler with thermostat	●	
Hyd. lock differential (front)	●	
Front axle cooling system	●	

POWER TRAIN	STD	OPT
Tires		
23.5 R25, L3	●	
23.5 - 25, 20PR, L3		●
23.5 - 25, 20PR, L5		●
23.5 R25, XHA2		●
20.5-25, 16PR, L3		●
Travel speed limiter (20-40 km/h)		●
HYDRAULIC SYSTEM		
Boom kickout, automatic	●	
Bucket positioner, automatic	●	
Diagnostic pressure taps	●	
Hydraulic oil cooler	●	
Hydraulic control, 2 spool	●	
Hydraulic control, 3 spool		●
Joystick Control (EH control)		●
Lever control-signle axle (EH control)		●
Joystick Steering		●
Ride control system		●
Secondary steering system		●
Extra piping-for auxiliary function		●
Quick coupler piping		●
Auto grease system		●
OTHER		
Articulation locking bar	●	
Counterweight	●	
Optional counter weight		●
Door and cab locks, one key	●	
Doors, service access(locking)	●	
Drawbar with pin	●	
Ergonomically located and slip resistant, left & right	●	
Handrails	●	
Ladders	●	
Platforms	●	
Steps	●	
Fenders(front / rear)	●	
Hydraulic oil level sight gauge	●	
Lift and tie-down hooks	●	
Loader linkage, sealed	●	
Z-bar design	●	
Vandalism protection caplocks	●	
Tool kit		●
Tooth, 1 piece, bolt-on type		●
Tooth, 2 pieces, bolt-on type		●
Cutting edge, bolt-on type	●	
Pallet forks		●
Guards		
Crankcase		●
Transmission		●
Mud guards		●
Wheel chock		●
License plate & lamp		●
Hi-Mate(Remote Management System)		●
Rearview camera		●
SAFETY		
Beacon light, rotating		●
Fire extinguisher		●
Operator suit		●

* Standard and optional equipment may vary. Contact your Hyundai dealer for more information. The machine may vary according to International standards.
 * The photos may include attachments and optional equipment that are not available in your area.
 * Materials and specifications are subject to change without advance notice.
 * All imperial measurements rounded off to the nearest pound or inch.

MOVING YOU FURTHER

HL955

With Tier4 Final / Stage IV Engine installed



*Photo may include optional equipment

HYUNDAI CONSTRUCTION EQUIPMENT
HEAVY INDUSTRIES

Head Office (Sales Office)
18TH FL., DIGITAL CUBE BLDG. 34, SANGAMSAN-RO, MAPO-GU, SEOUL 121-904, KOREA
TEL: 82-2-6424-1118 FAX: 82-2-6424-1129

Americas Operation : Hyundai Construction Equipment Americas, Inc.
6100 ATLANTIC BOULEVARD NORCROSS GA 30071 U.S.A
TEL: (1) 847-678-823-7802 FAX: (1) 847-678-823-7778

Europe Operation : Hyundai Heavy Industries Europe N.V.
VOSSENDAAL 11, 2440 GEEL, BELGIUM TEL: (32) 14-56-2200 FAX: (32) 14-59-3405



PLEASE CONTACT

www.hyundai-ce.com

2015. 02 Rev.0

Net Power

197 HP (147kW) / 2,200 rpm

Gross Power

200 HP(149kW) / 2,200 rpm

Travel Speed

38.5 km/hr (23.9 mph)

Operating Weight

15,100 kg

HYUNDAI
HEAVY INDUSTRIES



RULE THE GROUND

The HL Series wheel loaders are products of HHI's spirit of initiative, creativity, and strong drive. HHI's engineering experts have worked tirelessly to offer a zero-defect product. The new HL Series reflects customers' needs in the field gleaned by thorough monitoring. They maximize performance proven by rigorous field tests and quality control. The HL Series exceeds customers' expectations! Become a true leader on the ground with HHI's HL Series.



RULE THE GROUND

The HL series exceeds customer's expectation!
Become a true leader on the ground with HHI's HL series.

HL955



WORK MAX, WORTH MAX

- ECO Gauge
- ECO Pedal
- Engine Automatic Shut-Down (Option)
- Electro-Hydraulic Control (Option)
- New Weighing System
- Improved Bucket Fill Factor



MORE RELIABLE, MORE SUSTAINABLE

- Sealed Drive Line Center Bearing
- Sinter Brake Disc
- Durable Structure for After-Treatment
- Front Axle Oil Cooling System (Option)
- Hydraulic Hoses With Heightened Durability



INFOTAINMENT FRONTIER

- Intelligent & Wide Touch Screen Monitor
- Audio System
- Soft end Stop



MODERN COMFORT, SIMPLE AND SAFE SOLUTION

- New Air Conditioning System
- Fully Adjustable Seat Armrest, Seat, Control Lever
- Full Sound-Proofed Spacious Cabin
- E-H Control Lever (Option)
- Fully Sealed Engine Room & Fully Openable Engine Hood
- Centralized & Easy Access to Service Points
- Consolidated Initial Maintenance Interval



*Photo may include optional equipment.



UP to 5%

Greater productivity based on the 4th gear
(Compared to 9A Series)

UP to 10%

More fuel-efficient in truck loading
(Based on 5th speed T/M, Load&Carry Compared to 9A Series)

*Photo may include optional equipment.

New Weighing System

The HL Series further improves work precision with additional weight calibration. The automatic/manual cumulative weighing function greatly enhances operating efficiency. Icons displaying weighing errors and the two-color weight value indication on the monitor enable accurate weighing to support efficient production management.

WORK MAX, WORTH MAX

New Engine for Better Performance

Unparalleled performance realized by strong power at low speed and with excellent fuel efficiency! With more powerful performance, HHI's HL Series wheel loaders are 10% more fuel-efficient. They maximize productivity, demonstrating higher value in tough environments.



Eco Gauge

Eco Gauge enable economic operation of machines. The gauge level changes color with the engine torque and fuel efficiency level. On top of that, the status of fuel consumption such as average rate and the total amount of fuel consumed are displayed. Hourly and daily based fuel consumption can be checked in the detailed menu as well.



Automatic Shut-Down of Engine (Only Smart Key)

The HL Series turns off the engine when it enters the idling state to minimize unnecessary fuel consumption and emissions. Operators can select operating mode and idling time depending on work environments, further enhancing efficiency.

* Operating mode (one time/always/no use); idling time (2 to 40 minutes)

* Usable on button start sw (optional)



Eco Pedal

When operators use the accelerator pedal, the eco pedal, which can distinguish between economical operation and power operation, intuitively recognizes economical operation to reduce fuel consumption.

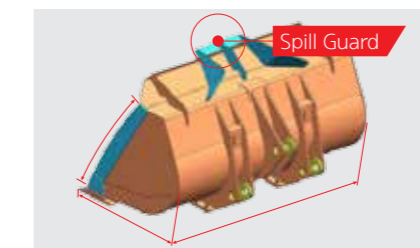

Improved Bucket Fill Factor

The bucket design was improved to increase bucket capacity and minimize spillage of loaded materials, greatly enhancing operating efficiency.



Electro-Hydraulic Control

With improved precision and operability, the electro-hydraulic control system of the HL Series provides diverse functions and easy handling to control any working conditions, increasing productivity and reducing fatigue of operators.

* Fine operation/bucket priority / Auxiliary attachment max flow / Soft end stop

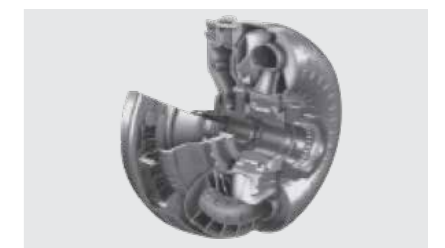

5 Speed Lock-up Clutch

By using of 5 speed & Lock up Clutch, now operator can enjoy both the reduction of consumption and various of use in gears depends on the working condition.

MORE RELIABLE, MORE SUSTAINABLE

New Exterior Design for More Robustness and Safety

The true value of the HL Series, which is now far more powerful, is revealed in tough working environments. With the high-strength design structure and enduring system proven by rigorous road tests at various work sites, HHI's wheel loaders can perform any high-load work to maximize productivity.



Durable Structure for After-Treatment

HHI's wheel loaders have a robust support and shock absorbing system to prevent failure of the aftertreatment system due to shock and vibration during operation, further improving durability.



Sinter Brake Disc

The HL Series has a sinter disc of a new material with excellent durability to suppress generation of heat and vibration, heightening brake durability and enabling convenient maintenance with a service-friendly design.



Hydraulic Hose

HHI's Hydraulic hoses have twice increased durability and product life cycle over previous hoses.

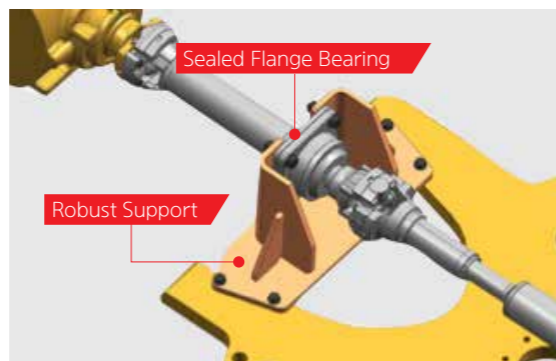

Sealed Drive Line Center Bearing

HHI's wheel loaders prolong the service life of equipment significantly. They have a sealed drive line center bearing with robust support to retain reliability in the long term.



Front Axle Oil Cooling System (Option)

A separate cooling system prevents overheating of axle oil caused by frequent braking and high-load work.

Hydraulic Hoses With Heightened Durability

The new HL Series has hydraulic hoses with outstanding heat and pressure resistance, greatly increasing durability.



*Photo may include optional equipment.

Wifi Direct With Smart Phone (Smart Terminal)

The Miracast system based on WiFi of the operator's smart phone enables easy and convenient use of various features of the smart phone on the big screen including navigation, web surfing, viewing of videos, and listening to music.

INFOTAINMENT FRONTIER

Enhanced Instrument Panel for Easier Monitoring

The HL Series is optimized to enable operators to access accurate equipment data in a timely manner. This feature is more important in tough working environments to increase productivity while enjoying various forms of entertainment. Enjoy unparalleled satisfaction provided by infotainment of HHI's state-of-the-art information technology!



Intelligent & Wide Touch Screen Monitor

The seven-inch capacitive-type display (like a smart phone display) of the HL Series is larger than the previous model and provides excellent legibility. Audio AUX maximizes convenience of operators.



Audio System

The radio player, integrated Bluetooth hands-free feature, and built-in microphone allow convenient and safe phone calls while in work and in driving.



Soft end Stop

When an attachment reaches at the end stroke, it gives operator enormous shock especially for Boom up. This function gives shock free operation by reducing the speed of attachment near the end stroke. It can be selected on/off through Monitor

MODERN COMFORT, SIMPLE AND SAFE SOLUTION

New Cabin for More Comfort

With top priority on satisfaction of operators in terms of silence, safety, and maintainability, HHI's wheel loaders provide comfortable cabin space for operators by low-vibration, low-noise, and superior safety design. They also offer greater satisfaction by extending the replacement cycle of supplies and minimizing maintenance time and cost.



Fully Adjustable Seat Armrest, Seat, Control Lever

The larger and more comfortable, luxurious with high quality seat (headrest standard; heated seat optional) and adjustable arm rest integrated with control levers for attachments make the cabin space comfortable and pleasant.



Full Sound-Proofed Spacious Cabin

State-of-the-art noise reduction technology of the HL Series ensures maximum silence (68 dB) in the same category of equipment, promising more silent and more pleasant interior space.



E-H Control Lever

HHI's wheel loaders have an electro-hydraulic implement control lever. Operators can operate attachments with less strength, enabling greater productivity and minimizing fatigue of operators.



New Air Conditioning System

HHI's wheel loaders maximize heating and cooling performance by optimizing air flow. The air conditioning system is placed on the right side of the cabin to ensure easy maintenance and filter replacement. The capacity of the inner filter was increased. Filter material was changed for superior filtering performance.



*Photo may include optional equipment.

Fully Sealed Engine Room & Fully Openable

The HL Series has improved accessibility to the sealed engine room with retractable hood to allow easy cleaning and maintenance. The engine room was designed to prevent possibility of fire due to inflow of foreign materials. The fully retractable engine hood in the electric cylinder opening mode also enhances maintainability of the engine room and cooling room.

Centralized & Easy Access to Service Points

All of the service points for the electric and hydraulic systems are located in easy to reach areas for accessibility and maintenance.

Consolidated Initial Maintenance Interval

The initial replacement cycle of oil and filter is extended to 250 hours to reduce maintenance costs.

Increased Service Life for Engine Air Filter

The HL Series has a large-volume air cleaner, an automatic dust ejector, and a three-stage turbo pre-cleaner (optional) to improve the replacement cycle and durability of supplies.

SPECIFICATIONS

ENGINE	
Maker/Model	CUMMINS / QSB6.7
Type	Watercooled, 4-cycle, turbocharged change aircooled, direct injection electronic controlled diesel engine
Gross power	200 HP(149kW) / 2,200 rpm
Net power	197 HP (147kW) / 2,200 rpm
Maximum torque	95 kg.m (685lb.ft) / 1,500 rpm
No. of cylinders	6
Bore x Stroke	107mm (4.21") x 124mm (4.88")
Displacement	6.7ℓ (409 cu in)
Compression ratio	17.3 : 1
Air cleaner	Dry, two stage dual elements
Alternator	Denso (24V-95Amp)
Battery	2 x 12V x 160Ah
Starting motor	Denso PA90L (24V-7.8kW)

TRANSMISSION	
Torque converter type	3-Elements, Single-stage, Single phase
Tire	20.5 R25, L3

* Full automatic power shift, countershaft type with soft-shift in range and direction. Properly matched torque converter to engine and transmission for excellent working ability

Travel speed, km/h (mph)	4 speed T/M	5 speed T/M with lock up clutch	
Forward	1st	6.9 (4.3)	6.4 (4.0)
	2nd	11.4 (7.1)	11.1 (6.9)
	3rd	23.0 (14.3)	17.1 (10.6)
	4th	38.5 (23.9)	26.6 (16.5)
	5th	-	40.0 (24.9)
Reverse	1st	7.3 (4.5)	6.7 (4.2)
	2nd	12.0 (7.5)	11.7 (7.3)
	3rd	24.3 (15.1)	28.0 (17.4)

AXLES	
Drive system	Four-wheel drive system
Mount	Rigid front axle and oscillating rear axle
Rear axle oscillation	Oscillation ± 11° of center pin-loaded
Hub reduction	Planetary reduction at wheel end
Differential	Conventional
Reduction ratio	23.680

OVERVIEW			
Description	UNIT	HL955	HL955XT
Operating weight	kg	15,100	15,600
	(lb)	(33,290)	(34,390)
Bucket capacity	Heaped	m³ (yd³)	2.4 (3.1)
	Struck	m³ (yd³)	2.8 (3.6)
Breakout force-bucket		kg	13,000
		(lb)	(28,660)
Tipping load	Straight	kg	11,580
		(lb)	(25,530)
	Full turn	kg	10,150
	(lb)	(22,380)	
			8,800
			(19,400)

TIRES	
Type	Tubeless, loader design tires
Standard	20.5 R25, ★, L3
Options include	20.5-25, 16PR, L2 20.5-25, 16PR, L3 20.5-25, 16PR, L5 17.5-25, 12PR, L3

HYDRAULIC SYSTEM	
Type	Load sensing hydraulic system
Pump	Variable displacement piston pump, 185 ℓpm
Control valve	2 Spool (Bucket, Boom) 3 Spool (Bucket, Boom, Aux)
System pressure	280 kgf/cm²
Lift Circuit	The valve has four functions : raise, hold, lower and float. Can adjust automatic kickout from horizontal to full lift.
Tilt Circuit	The valve has three functions : tilt back, hold and dump. Can adjust automatic bucket positioner to desired load angle.
Cylinder	Type : Double acting
	No. of cylinders-bore x stroke:
	Lift: 2-125mm (4.9") x 745mm (29.3") Tilt: 1-140mm (5.5") x 485mm (19.1") HL955 HL955XTD Tilt: 1-140mm (5.5") x 490mm (19.3")
Cycle Time	Raise: 5.8 sec Dump: 1.2 sec Lower: 3.8 sec Total: 10.8 sec

BRAKES	
Service Brakes	Hydraulically actuated, wet disc brakes actuate all 4 wheels independent axle-by-axle system. Self adjusting & wheel speed brake.
Parking Brake	Spring applied, hydraulic released brake
Emergency Brake	When brake oil pressure drops, indicator light alerts operator and parking brake automatically applies.

STEERING SYSTEM	
Type	Load sensing hydrostatic articulated steering
Pump	Variable displacement piston pump, 109 ℓpm
Relief Valve Setting	250 kgf/cm²
Cylinder	Double acting 2-65mm (2.6") x 418mm (16.5")
Steering Angle	40° to both right and left angle, respectively

Features
Center-point frame articulation. Tilt and telescopic steering column.

SERVICE REFILL CAPACITIES	
Fuel tank	250 liters (66 USgal)
DEF tank	27 liters (7.1 USgal)
Cooling system	42 liters (11.1 USgal)
Crankcase	18 liters (4.8 USgal)
Transmission	33 liters (8.7 USgal)
Front axle	32 liters (8.5 USgal)
Rear axle	24 liters (6.3 USgal)
Hydraulic tank	108 liters (28.5 USgal)
Hydraulic system (including tank)	188 liters (49.7 USgal)

DIMENSIONS

All dimensions are approximate.

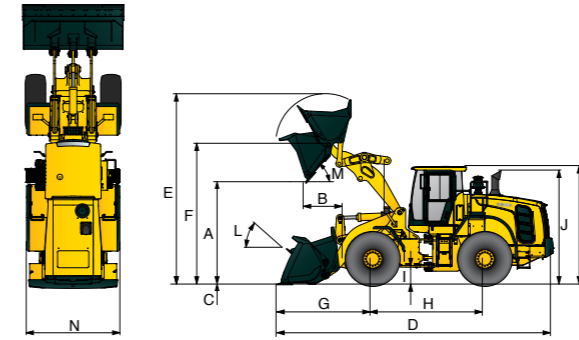

Description	UNIT	HL955	HL955XT	
Bucket Type	General purpose bolt-on cutting edge			
A. Dumping clearance at max. height and 45° dump angle.	mm (ft-in)	2,840 (9' 3.8")	3,235 (10' 7.4")	
B. Reach	Full lift	mm (ft-in)	1,125 (3' 8.3")	
	7ft height	mm (ft-in)	1,680 (5' 6.1")	
C. Digging depth	mm (in)	85 (3.3")	120 (4.7")	
	D. Overall length	mm (ft-in)	7,630 (25' 0")	8,040 (26' 4")
D. Overall length	on ground	mm (ft-in)	7,630 (25' 0")	8,040 (26' 4")
	at carry	mm (ft-in)	7,535 (24' 8.7")	7,985 (26' 2.4")

Description	UNIT	HL955	HL955XTD
E. Overall height (fully raised)	mm (ft-in)	5,380 (17' 7.8")	5,780 (18' 11.6")
F. Bucket pivot max. height	mm (ft-in)	3,940 (12' 11.1")	4,340 (14' 2.9")
G. Front overhang	mm (ft-in)	2,625 (8' 7.3")	3,035 (9' 11.5")
H. Wheelbase	mm (ft-in)	3,050 (10' 0.1")	3,050 (10' 0.1")
I. Ground clearance	mm (ft-in)	410 (1' 4.1")	410 (1' 4.1")
J. Height over exhaust	mm (ft-in)	3,273 (10' 8.9")	3,273 (10' 8.9")
K. Height over cab	mm (ft-in)	3,390 (11' 1.5")	3,390 (11' 1.5")
L. Roll-back angle	on ground	deg	43
	at carry	deg	48
M. Dump angle	deg	48	48
Clearance circle	mm (ft-in)	10,440 (34' 3.0")	10,440 (34' 3.0")
	N. Overall width	mm (ft-in)	2,740 (8' 11.9")
with bucket	with bucket	mm (ft-in)	2,580 (8' 5.6")
	without bucket	mm (ft-in)	2,580 (8' 5.6")

HL955/ DENSITY OF OPERATING MATERIALS

Loose Material	Material Density
Earth/Clay	1.5~1.7 (2528~2865)
Sand and Gravel	1.5~1.7 (2528~2865)
Aggregate	25~76mm(1" to 3in)
	19mm(3in) and larger
	1.6~1.7 (2697~2865)
	1.8 (3034)

HL955/ DENSITY OF OPERATING MATERIALS

Lift arm	Bucket	Type	m³ (yd³)	Material Density [t/m³] (lb/yd³)															
				1.0 (1686)	1.1 (1854)	1.2 (2023)	1.3 (2191)	1.4 (2360)	1.5 (2528)	1.6 (2697)	1.7 (2865)	1.8 (3034)	1.9 (3203)	2.0 (3371)	2.1 (3540)	2.2 (3708)	2.3 (3877)	2.4 (4045)	
Standard lift arm	General Purpose	Cutting edge	3.0 (3.9)	3.4m³ (4.4yd³)												2.8m³ (3.6yd³)			
		Cutting edge	2.8 (3.6)	3.1m³ (4.0yd³)												2.7m³ (3.5yd³)			
		1-Bolt on tooth	2.8 (3.6)	3.1m³ (4.0yd³)												2.7m³ (3.5yd³)			
		2-Bolt on tooth	2.8 (3.6)	3.1m³ (4.0yd³)												2.7m³ (3.5yd³)			
		1-Bolt on tooth	2.6 (3.4)	3.0m³ (3.9yd³)												2.5m³ (3.2yd³)			
		2-Bolt on tooth	2.6 (3.4)	3.0m³ (3.9yd³)												2.5m³ (3.2yd³)			
		1-Bolt on tooth & segment edge	2.8 (3.6)	3.1m³ (4.0yd³)												2.7m³ (3.5yd³)			
		2-Bolt on tooth & segment edge	2.8 (3.6)	3.1m³ (4.0yd³)												2.7m³ (3.5yd³)			
		Cutting edge	3.0 (3.9)	3.4m³ (4.4yd³)												2.8m³ (3.6yd³)			
		Cutting edge	2.8 (3.6)	3.1m³ (4.0yd³)												2.7m³ (3.5yd³)			
High lift arm (XTD)	General Purpose	1-Bolt on tooth	2.8 (3.6)	3.1m³ (4.0yd³)												2.7m³ (3.5yd³)			
		2-Bolt on tooth	2.8 (3.6)	3.1m³ (4.0yd³)												2.7m³ (3.5yd³)			
		1-Bolt on tooth	2.6 (3.4)	3.0m³ (3.9yd³)												2.5m³ (3.2yd³)			
		2-Bolt on tooth	2.6 (3.4)	3.0m³ (3.9yd³)												2.5m³ (3.2yd³)			
		1-Bolt on tooth & segment edge	2.8 (3.6)	3.1m³ (4.0yd³)												2.7m³ (3.5yd³)			
		2-Bolt on tooth & segment edge	2.8 (3.6)	3.1m³ (4.0yd³)												2.7m³ (3.5yd³)			

115% 100% 95%